



Ramsey Winch Company
 OWNER'S MANUAL
 ATV Electric Winch Model ATV2500



Note: Fairlead does not attach directly to winch. Winch shown with mounting plate, sold separately.

BADGER 2500 WINCH					
LAYER OF CABLE	1	2	3	4	5
Rated line pull per layer (lbs)	2500	2090	1800	1580	1400
(kgs)	1133	947	815	716	634
Cumulative cable capacity per layer (ft)*	7	15	25	37	50
(m)*	2.12	4.56	7.6	11.3	15.2
(3/16" - 4.8mm - dia. cable)					

*CABLE MUST BE UNIFORMLY WOUND ONTO DRUM.

Line pull (lbs)	NO	500	1000	1500	2000	2500
first layer (kgs)	LOAD	227	453	680	906	1133
Line speed (fpm)	18	17	15	12	11	7.5
first layer (mpm)	5.5	5.1	4.6	3.7	3.4	2.3
Amp draw (12v)	36	60	90	116	140	160

Congratulations

You have purchased the finest winch available in its service class. It features a highly efficient 3 stage planetary gear set which transmits torque from a permanent magnet motor. A safe positive clutch allows free spooling for quick cable deployment. Your Ramsey winch was designed and manufactured to provide you with the utmost in utility. As with any device that combines power and movement in its use, there are dangers if improperly used.

At the same time, there are easier and faster ways for getting the job done if certain precautions are taken first. Please read this manual carefully. It contains useful ideas in obtaining the most efficient operation from your Ramsey Winch and safety procedures you need to know

before beginning use. When you follow our guidelines for operation, your Ramsey winch will give you many years of satisfying service. Thank you for choosing Ramsey. You will be glad you have one working for you.

Please Note: Ramsey ATV 2500 winches are designed primarily for ATV use. This winch is not designed to be used in industrial applications (car haulers/carriers, wreckers, hoisting, etc.), and Ramsey does not warrant it to be suitable for such use. Ramsey makes a separate, complete line of winches for industrial/commercial use. Please contact the factory for further information.

 **CAUTION:** Read and understand this manual before installation and operation of winch. See Safety Precautions.

Contents	
Performance Specifications.....	1
Safety Precautions.....	2
Tips for Safe Operation.....	2
Techniques of Operation.....	3
General Installation.....	3
Winch Operation.....	4
Maintenance.....	4
Cable Installation.....	4
Troubleshooting Guide.....	5
Electrical Schematics.....	6-7
Wireless Remote Control Installation and Operation.....	8
Rocker Switch Operation.....	8
Rocker Switch Installation.....	8-10
Winch Parts List.....	12-14
Warranty.....	Back Cover

- I. Keep the duration of your pulls as short as possible. If the motor becomes uncomfortably hot to the touch, stop and let it cool for a few minutes. Do not pull more than one minute at or near the rated load. Do not maintain power to the winch if the motor stalls. Electric winches are for intermittent usage and should not be used in constant duty applications.
- J. Do not use winch in hoisting applications due to required hoist safety factors and features.
- K. Do not exceed maximum line pull ratings shown in tables. Shock loads must not exceed these ratings.
- L. To respool correctly, it is necessary to keep a slight load on the cable. Do not allow the cable to slip through your hand and do not approach the winch too closely. When all the cable except a few feet is in, stop and finish spooling in cable by rotating the drum by hand with clutch disengaged. Always use hook strap to hold hook when spooling.



Safety Precautions To Guard Against Possible Injury

- A. Keep yourself and others a safe distance to the side of the cable when pulling under load.
- B. Do not step over a cable, or near a cable under load.
- C. Use supplied hook strap when handling hook for spooling wire rope.
- D. Do not use ATV to pull a load on the winch cable. This could result in cable breakage and/or winch damage.
- E. Use a heavy rag or gloves to protect hands from burrs when handling winch cable.
- F. Apply blocks to wheels when ATV is on an incline.
- G. Winch clutch should be disengaged when winch is not in use and fully engaged when in use.
- H. Modification, alteration, or deviation to the winch should only be made by Ramsey Winch Company.

Tips for Safe Operation

Don't underestimate the potential danger in winching operations. Neither should you fear them. Do learn the basic dangers and avoid them.

Observe spooling of cable onto drum. Side pulls can cause cable to pileup at one end of the drum. To correct uneven stacking, spool out that section of the cable and move it to the other end of the drum and continue winching. Uneven spooling which causes cable pileup can interfere with the winch tie rods causing damage to the winch.

Store the wireless remote control transmitter in a safe place where it will not become damaged. Inspect it before you use it.

When ready to begin winching, push and hold the On/Off button on the transmitter until it flashes. Do not engage clutch with motor running.

Never connect the hook back to the cable. This causes cable damage. Always use a sling or chain of suitable strength.

Observe your winch while winching, if possible, while standing at a safe distance. If you use vehicle drive to assist, stop and get out every few feet to assure the cable is not piling up in one corner. Jamming cable can break your winch.

When double lining during stationary winching, do not attach tow hooks to winch mounting plate.

Since the greatest pulling power is achieved on the innermost layer of your winch, it is desirable to pull off as much line as you can for heavy pulls. If this is not practical, use a snatch block and double line arrangement.

Neat, tight spooling avoids cable binding which is caused when a load is applied and the cable is pinched between two other wraps of cable. If this happens, alternately power the winch in and out a few inches. Do not attempt to work a bound cable under load, free by hand.

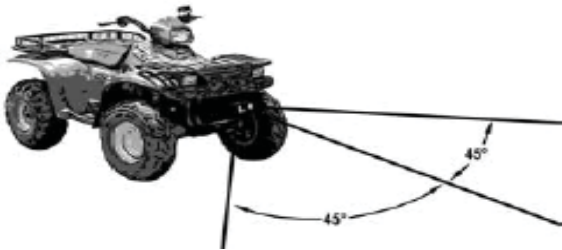

Winches equipped with cable guide fairleads can pull from several directions. Pull from an angle only to straighten up the ATV—otherwise you can damage structural members or other parts of the ATV and cause excess cable buildup on one end of the winch drum.

General Installation

The winch shown in this owners manual is designed solely and exclusively for ATV-mounted, non-industrial applications. All other applications will void warranty.

1. Install Winch and Mounting Kit according to instructions supplied with Mounting Kit. Tighten mounting bolts to 16 ft-lbs (22 Nm) torque.
2. **It is very important that the winch be mounted on a flat surface, with the cable feeding from the bottom of the drum.**

Techniques of Operation

The best way to get acquainted with how your winch operates is to make a few test runs before you actually need to use it. Plan your test in advance. Remember you hear your winch as well as see it operate. Get to recognize the sound of a light steady pull, a heavy pull, and sounds caused by load jerking or shifting. Soon you will gain confidence in operating your winch and its use will become second nature to you.

Your winch will not only pull your ATV up or ease your ATV down a steep grade, it will also pull another ATV or a load while your ATV is anchored in a stationary position.

When pulling a heavy load, place a blanket, jacket, or tarpaulin over the cable five or six feet from the hook. It will slow the snap back in the event of a broken cable.

Use the ATV wheel power to help the winch, but don't overtake the winch line. Plan your pull. You can't always hook up and pull out in one step. Examine all the areas for anchoring possibilities as well as leverage situations, direction, and goal.



For basic self-recovery, anchor to a tree or rock. When anchoring to a tree, always use a tree trunk protector..

CAUTION: SUPPLIED 7/8" LONG MOUNTING BOLTS WITH LOCKWASHERS ARE FOR A RECOMMENDED WINCH MOUNTING PLATE THICKNESS OF 3/16". IF A DIFFERENT MOUNTING PLATE THICKNESS IS USED, THE BOLT LENGTH MUST BE ADJUSTED ACCORDINGLY OR DAMAGE TO WINCH MAY OCCUR. REPLACEMENT BOLTS MUST BE SAE GRADE 5 OR EQUIVALENT.

3. Do not attach motor and battery leads until instructed to do so.
4. Refer to installation instructions for the Wireless Remote switch (in the *ATV Wireless Installation and Operation Manual*) for electrical connections and installation.

Winch Operation

The winch clutch allows rapid unspooling of the wire rope for hooking onto the load or anchor point. The clutch is operated by the shifter located on the end of the winch as follows:

1. To disengage the clutch, turn the clutch shifter to the "FREESPOOL" position. Wire rope may now be freespoiled off the drum.
2. To engage the clutch, turn the clutch shifter to the "ENGAGED" position. The winch is now ready for pulling.



Your battery must be kept in good condition. A fully charged battery and proper connections are essential. Run the vehicle engine during winching operations to keep battery charged.

Maintenance

Corrosion on electrical connections will reduce performance or may cause a short. Clean all connections. In salty environments use a silicone sealer to protect from corrosion.

See supplied instructions for programming a replacement transmitter.

All moving parts in the winch are permanently lubricated with broad temperature range lithium-based grease.

Lubricate cable periodically using light penetrating oil. Inspect for broken strands and replace if necessary. If the cable becomes worn or damaged, it must be replaced.

To minimize corrosion of the internal motor components that may occur due to condensation, power the winch in or out periodically. Energizing the motor will generate heat, which will dissipate any moisture buildup in the motor. This should be performed at periodic intervals (such as with each oil change of your vehicle). Note: Refer to the Troubleshooting Guide if the motor has been submerged.

Cable Installation

Note: Cable should be installed so that it feeds from the bottom of the drum.

Unwind the new cable by rolling it out along the ground to prevent kinking. Remove old cable and observe the manner in which it is attached to the cable drum flange, watching carefully for the cable anchor puck.

Before installing the new cable assembly, securely wrap the end of the cable with tape to prevent fraying.

Slide the cable through narrow end of the pocket against drum flange and wrap the cable around the anchor puck. Pull the cable and anchor back into the wide end of the pocket leaving approximately 1/8" beyond edge of pocket as shown. Use a hammer and drift punch to drive the back side of the wire rope, firmly seating the wire rope and anchor into the pocket.

Wind on the cable by pulling in a light load to keep the tension constant. Allow the cable to swivel by using a length of chain or a swivel block between the cable hook and the load.

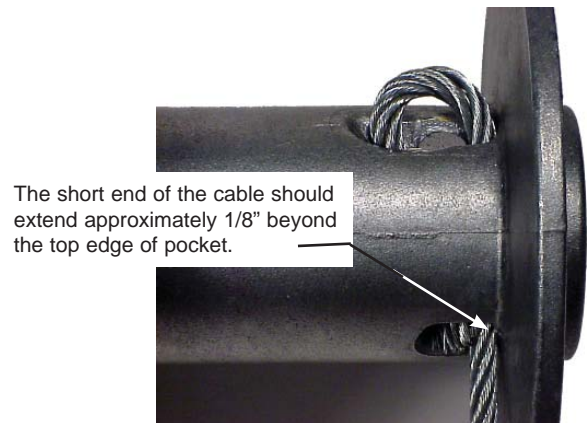

Troubleshooting Guide

CONDITION	POSSIBLE CAUSE	CORRECTION
MOTOR RUNS IN ONLY ONE DIRECTION	<p>Defective solenoid or stuck solenoid.</p> <p>Defective remote control or low battery in transmitter.</p>	<p>Jar solenoid assy to free contacts. Check each solenoid by applying +12 volts to coil terminal (it should make an audible click when energized).</p> <p>Check winch operation with auxiliary toggle switch. Check battery in transmitter.</p>
MOTOR RUNS EXTREMELY HOT	Long period of operation.	Cooling-off periods are essential to prevent overheating.
MOTOR RUNS, BUT WITH INSUFFICIENT POWER OR WITH LOW LINE SPEED	<p>Insufficient battery</p> <p>Bad connection</p> <p>Insufficient charging system.</p>	<p>Test for faulty vehicle battery.</p> <p>Check battery cable for corrosion; clean and grease</p> <p>Replace with larger capacity charging system.</p>
MOTOR RUNS, BUT DRUM DOES NOT TURN	Clutch not engaged.	If clutch engaged but symptoms still exist, it will be necessary to disassemble winch to determine cause and repair.
MOTOR WILL NOT OPERATE	<p>Stuck or defective solenoid.</p> <p>Defective remote control or low battery in transmitter.</p> <p>Defective motor.</p> <p>Loose connections.</p>	<p>Jar solenoid assy to free contacts. Check solenoid by applying +12 volts to coil terminal (it should make an audible click when energized).</p> <p>Check winch operation with auxiliary toggle switch. Check transmitter battery</p> <p>If solenoids operate, check for voltage at armature post; replace motor.</p> <p>Check all electrical connections from the battery to the motor.</p>
MOTOR WATER DAMAGED	Submerged in water or water from high pressure car wash.	Allow to drain and dry thoroughly, then run motor without a load in short bursts to dry windings.
WINCH RUNS IN OPPOSITE DIRECTION OF TRANSMITTER BUTTONS	<p>Motor leads crossed.</p> <p>Solenoid control wires crossed.</p>	<p>Reverse electrical connections to motor.</p> <p>Reverse position of green and yellow wires on solenoid assy.</p>

Electrical Schematic - Wireless Remote only

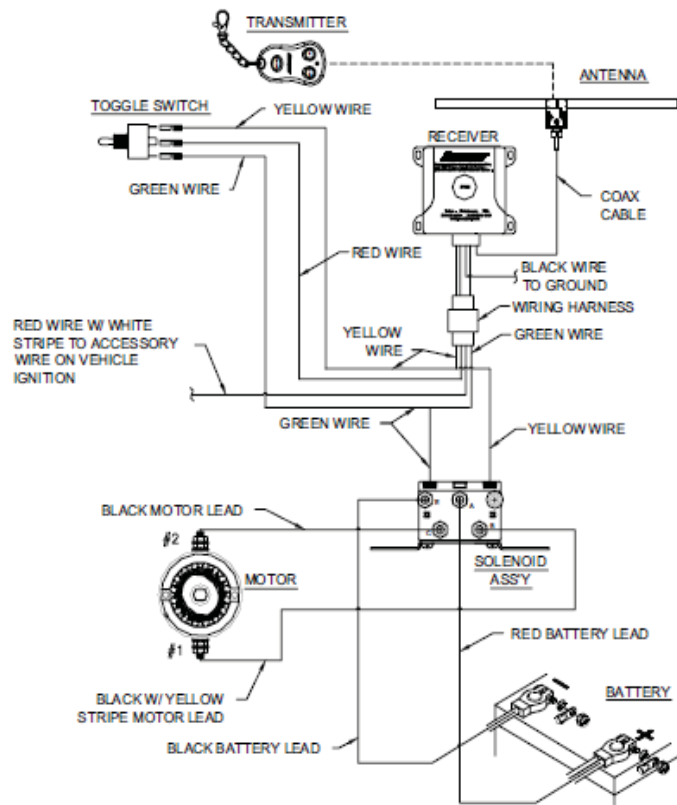

Electrical Schematic - Rocker Switch only

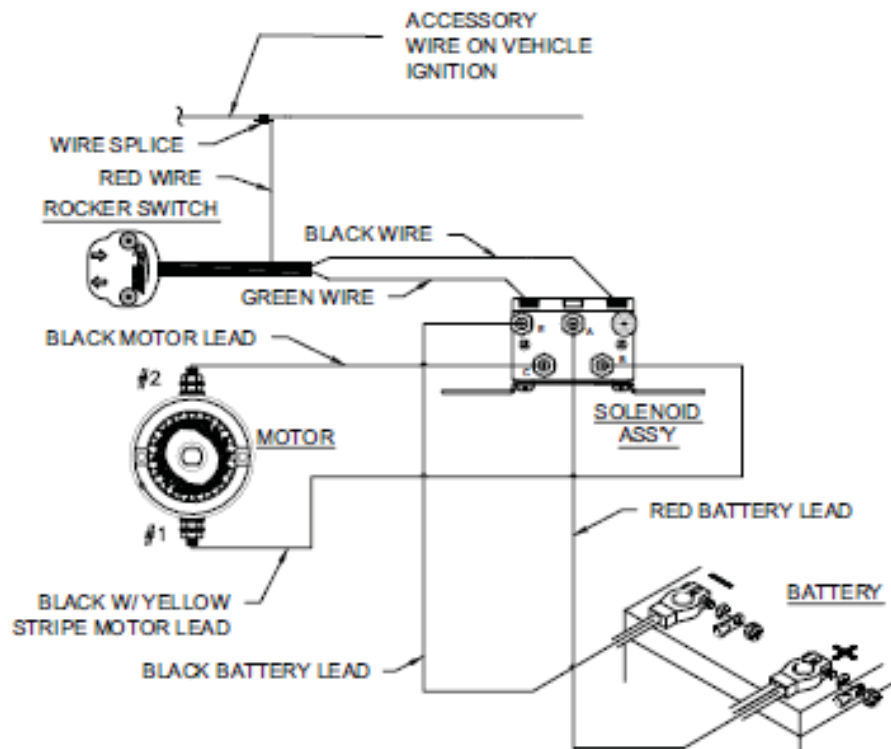

Electrical Schematic - Wireless Remote and Rocker Switch

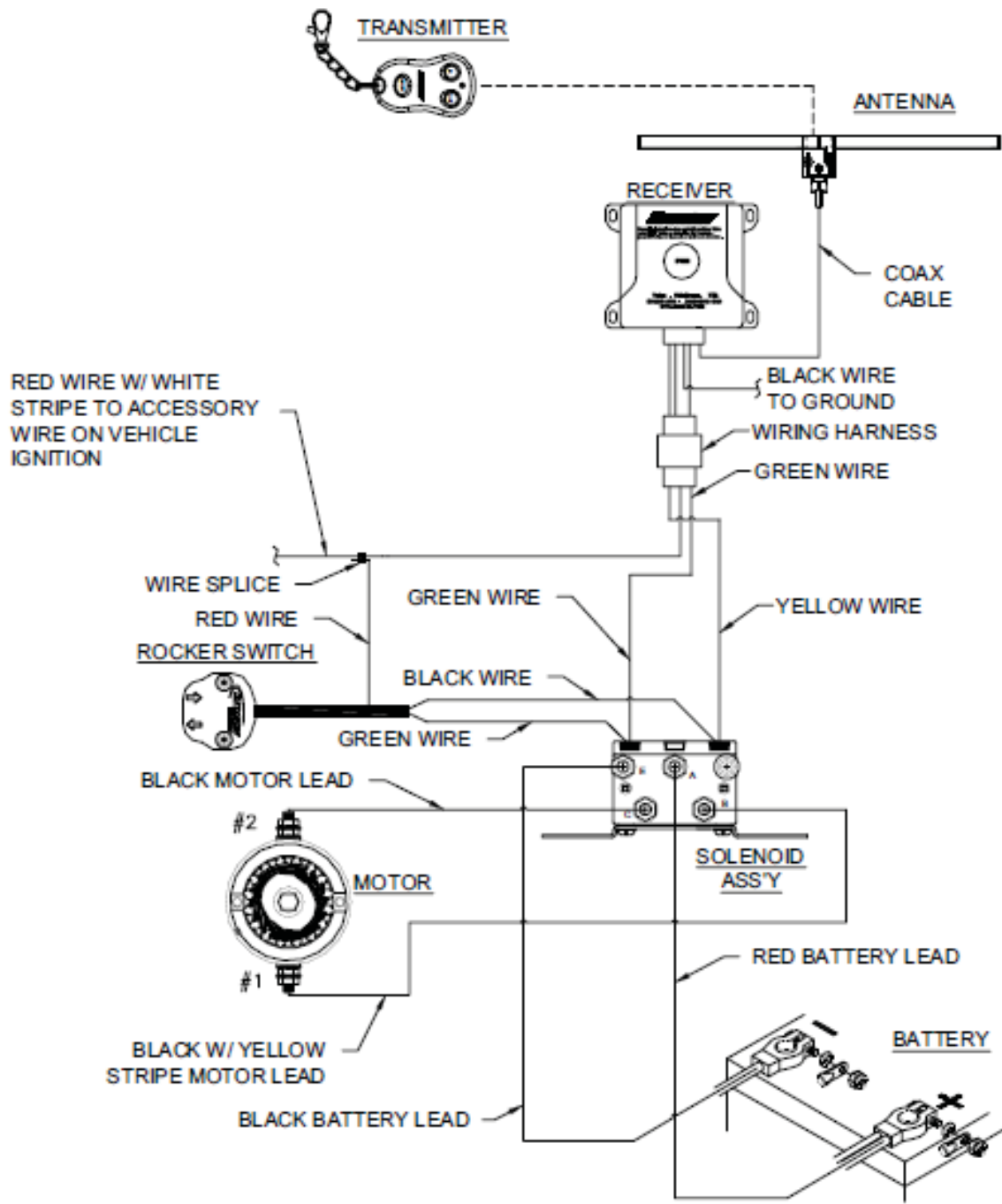

For certain mounting applications, where the solenoid needs to be mounted at the rear of the vehicle, switch the battery and motor leads. In this case, connect the black w/yellow stripe lead to the positive (+) terminal of the battery, and the longer black lead to the negative (-) terminal. Connect the red lead and the shorter black lead to the motor terminals.

Wireless Remote Control Installation and Operation

If your winch includes a Wireless Remote Control, refer to pages 2-4 of Wireless Remote Control Installation Instructions for instructions for installing the solenoid, receiver, antenna, and toggle switch. Install the Wireless Remote Control before the Rocker Switch, if using both.

Refer to page 6 of Wireless Remote Control Installation Instructions for remote operation notes.

Caution: When the transmitter reaches a temperature below 0°F (-18°C) it will not operate. In extremely cold temperatures, keep transmitter in a pocket of innermost layer of clothing when not in use.

The transmitter has push buttons labeled according to their function. Make sure the motor has stopped fully before reversing to prevent premature solenoid failure. To operate the winch hold "ON/OFF" button for 2 seconds to activate the "IN and "OUT" functions. Run winch forward and reverse to check connection and to verify winch operating directions. The transmitter is clearly labeled and a red LED flashes when the winch is in operation. Pushing both buttons at the same time will not damage your winch in any way.



Press and hold the "ON/OFF" button on the transmitter to disable the transmitter when winch is not in use. This will prolong the battery life of the transmitter. The transmitter automatically turns off after 20 minutes.

Rocker Switch Operation

Press Rocker Switch toward "IN" position to spool cable "IN" and press Rocker Switch toward "OUT" position to spool cable "OUT".

Rocker Switch Installation

Before Beginning Installation

1. **Disconnect negative (-) battery cable from battery. Turn off vehicle ignition. Disengage winch clutch.**
2. Remove hood or cowling as necessary for easier access to installation area.
3. Locate and mark mounting location for Solenoid Assembly. Choose a mounting location that will remain protected and dry. Solenoid must be mounted within 24" of winch motor. Solenoid should be mounted on a flat surface.
4. Locate accessory wire from vehicle ignition switch that is powered only when ignition is ON. Use this wire when splicing to Red wire on Rocker switch.
5. Make sure locations are close enough for wiring connections to be made without making alterations to wire lengths.

CAUTION: DO NOT CONNECT NEGATIVE BATTERY CABLE OR ENGAGE CLUTCH UNTIL INSTALLATION IS COMPLETE. WINCH COULD BEGIN SPOOLING CABLE UNEXPECTEDLY CAUSING INJURY OR DAMAGE TO WINCH.

Installing the Solenoid

(If installing Wireless Remote, install solenoid according to instructions in Wireless Remote Installation Instructions)

1. Either use Solenoid Assembly as a guide to mark and drill (2) 7/32" holes in location determined for solenoid or use Tube clamps (item #18-15) to mount it.
2. Use (2) 3/4" long #10 screws (item #18-11), (2) #10 flat washers (item #18-16), and (2) #10 zinc locknuts (item #18-4) to mount solenoid. Tighten to 60 in-lbs (7 Nm) torque.

Installing the Rocker Switch

For clarification, see wiring schematic on pages 6-7.

1. Install green Wire Connector (item #18-20) to green wire on Rocker Switch (item #17) and black Wire Connector (item #18-19) to black wire on Rocker Switch, as shown at right.

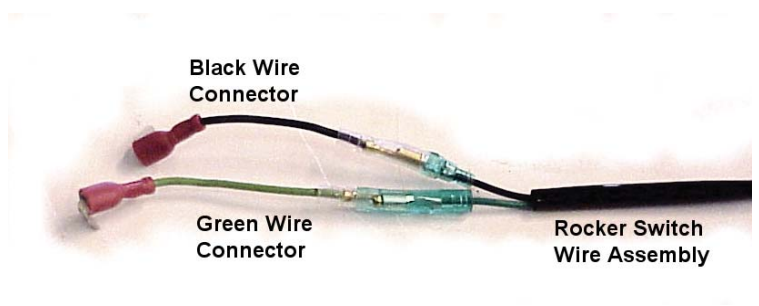

2. The Rocker Switch assembly (item #17) will be assembled with the two halves of the housing already attached. Install the Mounting Bracket (item #18-8) using (2) #6 screws (item #18-12) and shake-proof washers (item #18-18). See figure below. Tighten securely. Do not overtighten.

3. Install (2) Handle Bar Clamps (item #18-2) around ATV handle bars at a convenient location. Use a 3/4" long #10 screw (item #18-11) and #10 locknut (item #18-3) to secure them. See figure below and at right. Secure loosely, do not tighten.

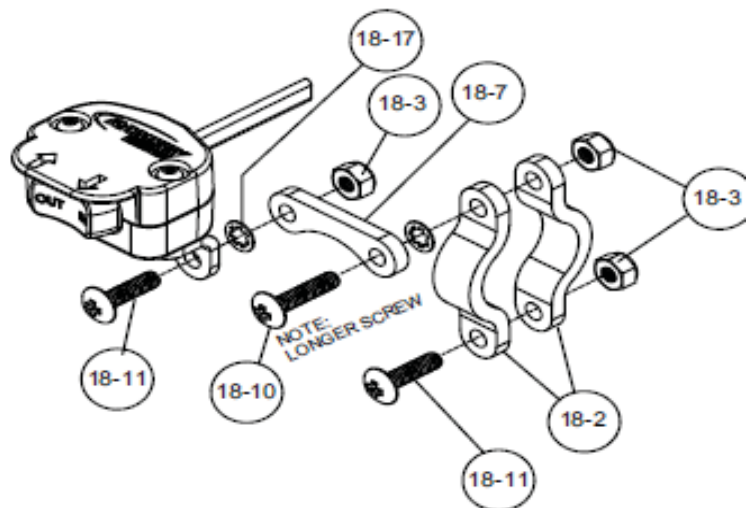
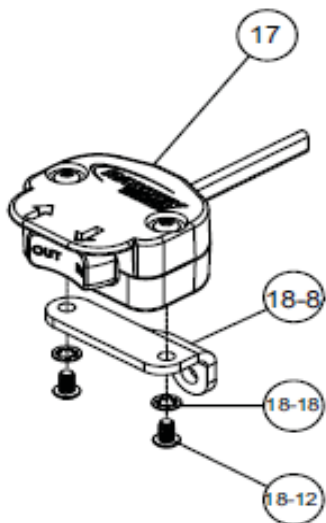
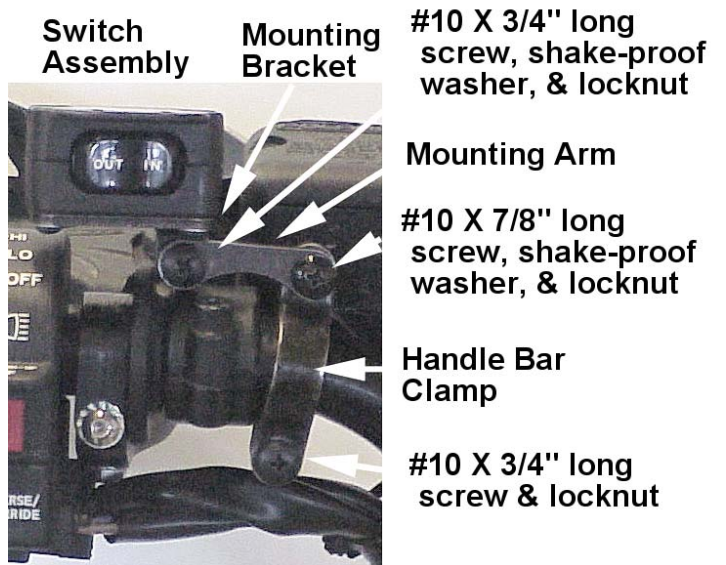

4. Install the Mounting Arm (item #18-7) to the Handle Bar Clamps using a 7/8" long #10 screw (item #18-10), shake-proof washer (item #18-17), and locknut (item #18-3). Install the shake-proof washer between the handle bar clamps and the mounting arm. Do not tighten.
 5. Install the Mounting Bracket (with rocker switch attached) to the Mounting Arm Bracket using a 3/4" long #10 screw, shake-proof washer, and locknut. Install the shake-proof washer between the mounting arm bracket and the mounting bracket.
 6. Tighten all screws for the handle bar clamps and mounting brackets securely, positioning the rocker switch as desired.
 7. Route the Rocker Switch wire down the handle bars to where the solenoid is mounted. Turn the handle bars fully right and left to ensure enough slack in the wire. Make sure wire is not drawn taut across any surface that could damage it. Use cable ties to anchor wire. Do not connect wires to solenoid yet.
 8. Push ATV Accessory wire and red wire from switch into plastic splice (item #18-21). Fold splice clip over itself and snap closed.
3. Connect Black Battery Lead to "E" terminal on Solenoid and route to negative (-) vehicle battery terminal **but do not connect**.
 4. Plug black wire from switch into right terminal (terminal above black with yellow stripe motor lead). Plug Green wire from switch into left terminal (terminal above black motor lead). If the Wireless Remote is installed, unplug the wires from the solenoid, connect the switch wires, then plug the wires from the wiring harness into the "piggyback" connectors above the switch wires.

Finish Installation

1. Confirm that winch clutch is disengaged.
2. Connect negative (-) battery cable to vehicle battery. Connect Black Battery Lead from winch to negative (-) vehicle battery terminal.
3. With ignition switch OFF, press Rocker switch to "OUT"—winch should not operate. If the winch does operate with the ignition off, confirm that proper accessory wire from ignition was spliced.
4. Spool a few feet of cable out by hand. Engage winch clutch. Turn ignition switch ON and press Rocker switch to "OUT"—winch should spool cable out. If winch does not operate with ignition on, check wiring against the schematic on pages 6-7.
5. If winch spools cable IN instead of OUT, turn off ignition and reverse black and green wires on solenoid.

Connect Wiring to Solenoid

CAUTION: TIGHTEN NUTS ON TERMINAL STUDS TO 35-40 IN-LBS. (3-4 NM) TORQUE. Do NOT OVERTIGHTEN.

For clarification, see wiring schematics on pages 6-7. If installing the Wireless Remote Control, install the solenoid according to the instructions in the Wireless Remote Control Installation Instructions.

1. Connect Red Battery Lead between "A" terminal on Solenoid and positive (+) vehicle battery terminal.
2. Connect Black Motor Lead between #2 terminal on motor and C terminal on solenoid. Connect Black w/Yellow Stripe Motor Lead between #1 terminal on motor and B terminal on solenoid.

NOTES

ATV2500 Parts List

ITEM NO.	QTY	PART NO.	DESCRIPTION
1	1	251214	MOTOR KIT
2	1	251247	MOTOR END GEAR SET KIT
3	1	251191	CLUTCH KIT
4	1	251192	CABLE DRUM KIT
5	1	251193	CABLE & HOOK KIT
6	1	251213	CLUTCH END GEAR KIT
7	1	251236	ROLLER FAIRLEAD KIT
8	1	251195	BUSHING KIT
9	1	251196	TIE BAR KIT
10	1	251197	ELECTRICAL WIRING KIT
11	1	282058	WIRELESS RECEIVER & TRANSMITTER KIT
12	1	251190	WIRELESS TRANSMITTER KIT
13	1	251234	SOLENOID KIT
14	1	251235	TOGGLE SWITCH KIT
15	1	251198	ANTENNA KIT
16	1	256116	BRAKE KIT
17	1	282065	ROCKER SWITCH
18	1		*HARDWARE KIT

ATV 2500 PARTS

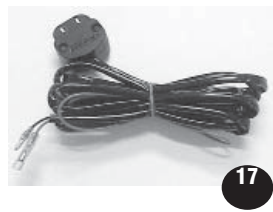
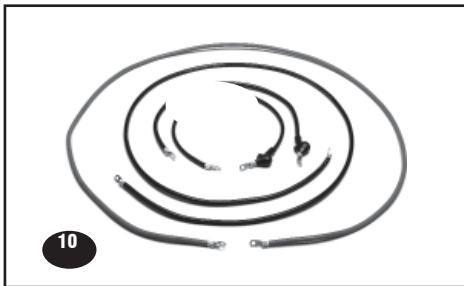
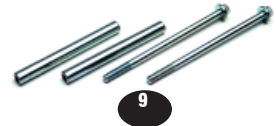
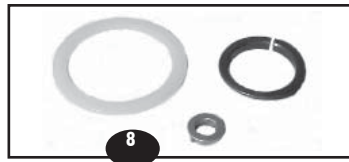
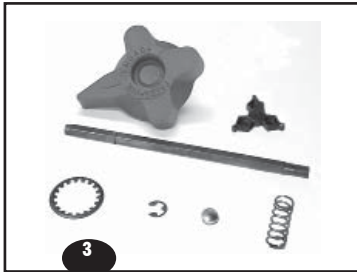
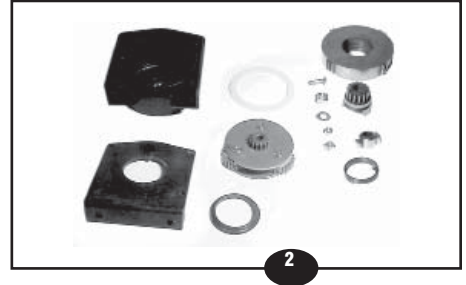
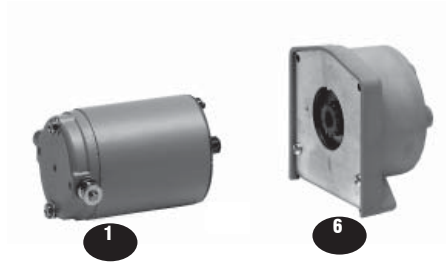

* 18. Hardware Kit

Item

No.	Qty.	Description
18-1	1	CABLE TIES, PKG. (NOT PICTURED)
18-2	2	HANDLE BAR CLAMP BRACKET
18-3	3	LOCKNUT - #10-24NC HEX BLACK
18-4	2	LOCKNUT - #10-24NC HEX ZINC
18-5	2	LOCKWASHER - 3/8 MED SECTION ZINC (FAIRLEAD MTG)
18-6	4	LOCKWASHER - 5/16 MED SECTION ZINC (WINCH MTG)
18-7	1	MOUNTING ARM BRACKET
18-8	1	MOUNTING BRACKET
18-9	2	NUT - 3/8-16NC REG HEX ZINC (FAIRLEAD MTG)
18-10	1	SCREW - #10-24NC X 7/8" LG TRUSS, CROSS RECESS BLACK
18-11	4	SCREW - #10-24NC X 3/4" LG TRUSS, CROSS RECESS BLACK
18-12	2	SCREW - #6-32NC X 1/4" LG SOCKET BUTTON HEAD BLACK
18-13	2	SCREW - 3/8-16NC X 1" LG HEX HEAD GR5 ZINC (FAIRLEAD MTG)
18-14	4	SCREW - 5/16-18NC X 1" LG HEX HEAD GR5 ZINC (WINCH MTG)
18-15	2	TUBE CLAMP
18-16	2	WASHER - #10 FLAT ZINC
18-17	2	WASHER - #10 SHAKE PROOF
18-18	2	WASHER - #6 SHAKE PROOF
18-19	1	WIRE ASSEMBLY - BLACK
18-20	1	WIRE ASSEMBLY - GREEN
18-21	2	WIRE SPLICE



2

Black



3

Zinc



4



5



6



7



8



9



10



11



12



13



14



15



16



17



18

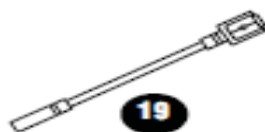

19

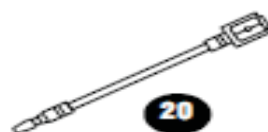

20



21

NOTES

Warranty Information

Ramsey Winches are designed and built to exacting specifications. Care and skill go into every winch we make. If the need should arise, warranty procedure is outlined on the back of your self-addressed, post-age paid warranty card. Please read and fill out the enclosed warranty card and send it to Ramsey Winch Company. If you have any problems with your winch, please follow instructions for prompt service on all warranty claims.

Limited Lifetime Warranty

Ramsey Winch offers a limited lifetime warranty for each new Ramsey winch against manufacturing defects in workmanship and materials on all manufactured components.

Warranty registration cards for each winch must be submitted at the time of purchase, or within 90 days. Online registration of your winch is available at www.ramsey.com.

New cable assemblies are warranted against defects in workmanship and materials. No warranty applies after initial use.

All Ramsey mounting kits and other accessories carry a 1- year limited warranty against defects in materials and workmanship.

This warranty is void if winch is used in industrial applications.

Electrical components consisting of motors, solenoids, wiring, wire connectors, and associated parts carry a limited 1-year warranty.

The obligation under this warranty, statutory or otherwise, is limited to the replacement or repair at the manufacturers factory, or at a point designated by the manufacturer, of such part as shall appear to the manufacturer, upon inspection of such part, to have been defective in material or workmanship. This Warranty does not obligate Ramsey Winch Company to bear the cost of transportation charges in connection with the replacement or repair of defective parts, nor shall it apply to a product upon which repairs or alterations have been made, unless authorized by the manufacturer, or for equipment misused, neglected, or improperly installed.

Important notice: To the fullest extent permitted by applicable law, the following are hereby excluded and disclaimed: 1. All warranties of fitness for a particular purpose; 2. All warranties of merchantability; 3. All claims for consequential or incidental damages. There are no warranties that extend beyond the description that appears on the face hereof.

Some states do not allow the above exclusions or disclaimers in consumer transactions and as such this disclaimer/exclusion may not apply to your particular case.

To the extent such warranties of fitness for a particular purpose or merchantability are deemed to apply to this product, they exist only for so long as the express limited warranty elsewhere set forth is in existence.

Ramsey Winch Company makes no warranty in respect to accessories, same being subject to the warranties of their respective manufacturers.

Ramsey Winch Company, whose policy is one of continuous product improvement, reserves the right to improve any product through changes in design or materials as it may deem desirable without being obligated to incorporate such changes in products of previous manufacture.

If field service at the request of the buyer is rendered and the fault is found not to be with Ramsey Winch Company's product, the buyer shall pay the time and expense of the field representative. Bills for service, labor or other expenses which have been incurred by the buyer without express approval or authorization by Ramsey Winch Company will not be accepted.

This Warranty gives you specific legal rights and you may also have other legal rights which vary from state to state.



RAMSEY WINCH COMPANY

P.O. BOX 581510 TULSA, OKLAHOMA 74158-1510 USA

PHONE: (918) 438-2760 FAX: (918) 438-6688

<http://www.ramsey.com>

OM-914159-0813-C